



1982-93 S10 / Syclone

4 Panel Sequential LED Taillight Kit w/LED Reverse Installation Guide

Kit Contents:

- 4 LED panels
- 4 black grommets
- 1 12v power wire
- 1 pigtail harness kit
- 1 crimp terminal kit
- 4 mounting brackets
- 2 red 194 LED bulbs

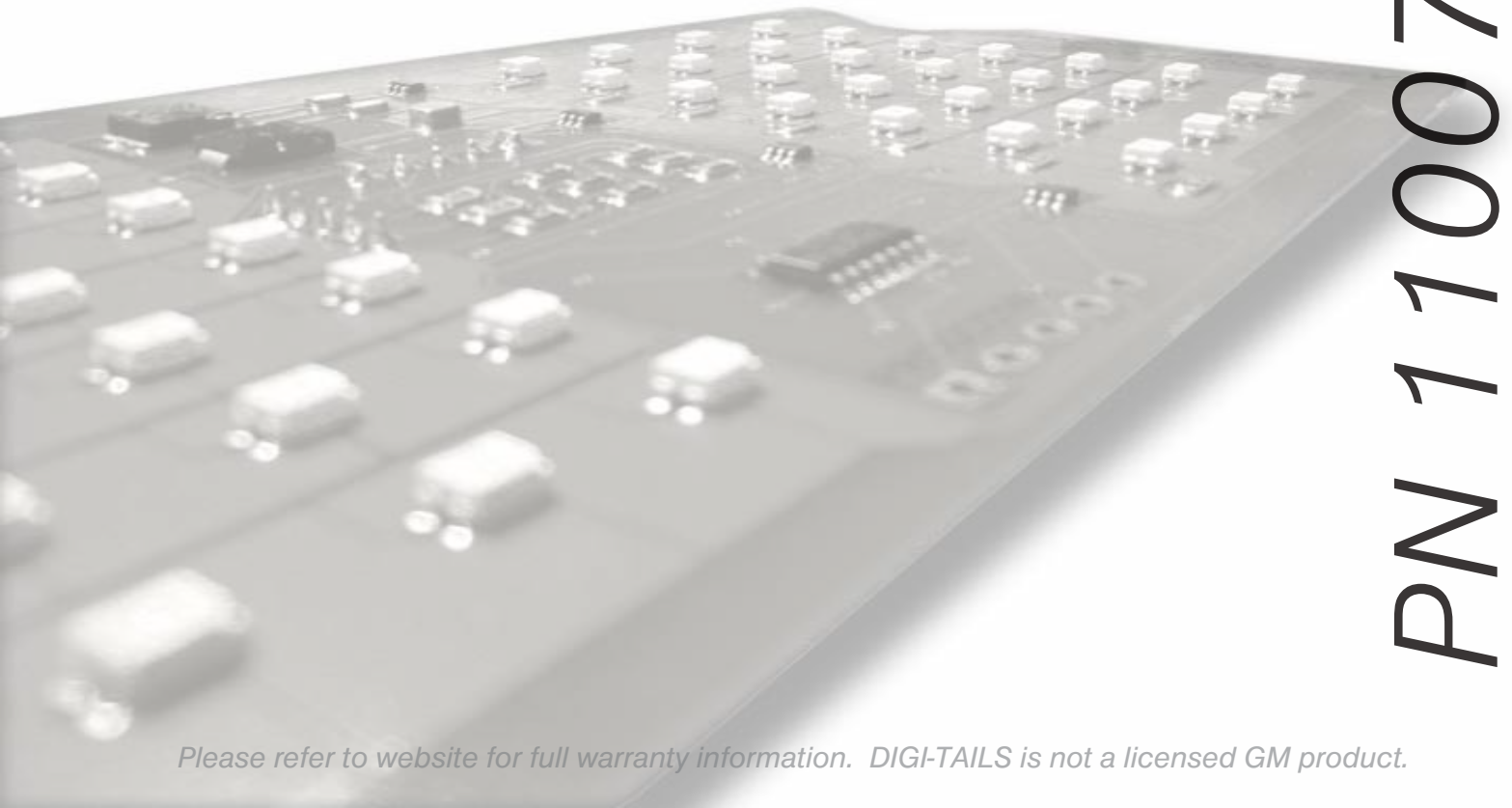

P/N 1100782

All LED panels are shipped with the slide switch set to SEQUENTIAL mode. The slide switches must be set to the same setting (either standard or sequential). Please follow all local laws concerning exterior lighting.



SLIDE SWITCH

You may begin with the LED panel installation, however, you will need to complete the wiring modifications before the LED panels and housings are paired as one. Read over the entire instruction guide to determine the method that works best for you.

If you have any questions give us a call or e-mail us. We can e-mail out more in depth troubleshooting notes, bench test procedures, and diagrams. You can also message us on Face book, @DIGI-TAILS, with your questions.

E-MAIL: INFO@DIGI-TAILS.com **TECH:** TECH@DIGI-TAILS.com **PHONE:** 1-856-719-9989

All cars are either equipped with Combined Signals or Separate Signals. Verify that the LED taillight kit matches your car. In almost all instances our respective kits match your car. In the rare case it does not please contact us.

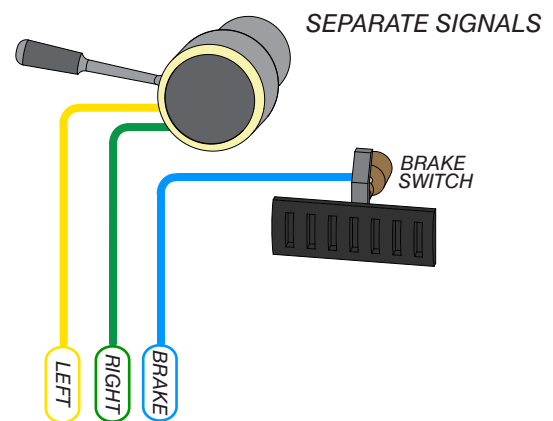
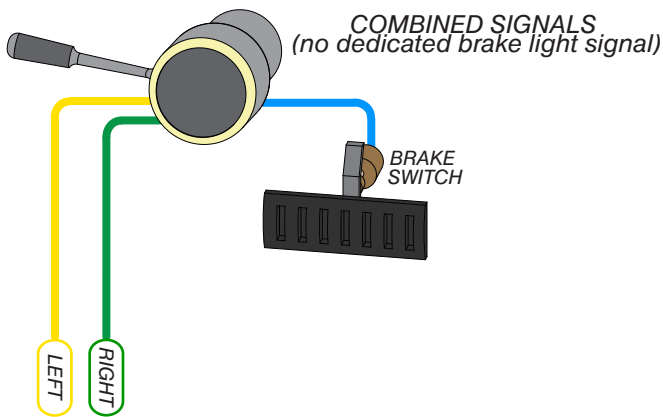

A Common question we get is; Why do all COMBINED signal LED taillight kits need both driver and passenger signals? Answer; All panels need both driver and passenger signals so that the circuitry on each panel knows if you are using the brakes or turn signals. This then allows the panels to run a sweeping motion for the turn signal and a separate sequence for the brakes.

Be sure to power up all LED panels and test all functions before any final installation.

If turn signals light up solid with no flash then check the flasher unit polarity as it may be reversed.

If LED panels don't operate properly once the park/run lights or headlights are on then the park/run wire may be crossed with other signal wires.

NOTE ALL PANELS ARE MARKED DRIVER OR PASSENGER FOR BOTH BRAKE AND REVERSE.

For easier reference, the following procedure outlines the full install process for the Brake panel and then the Reverse Panel. However all cutouts, wiring, and testing should be done before any final mounting of any individual panel.

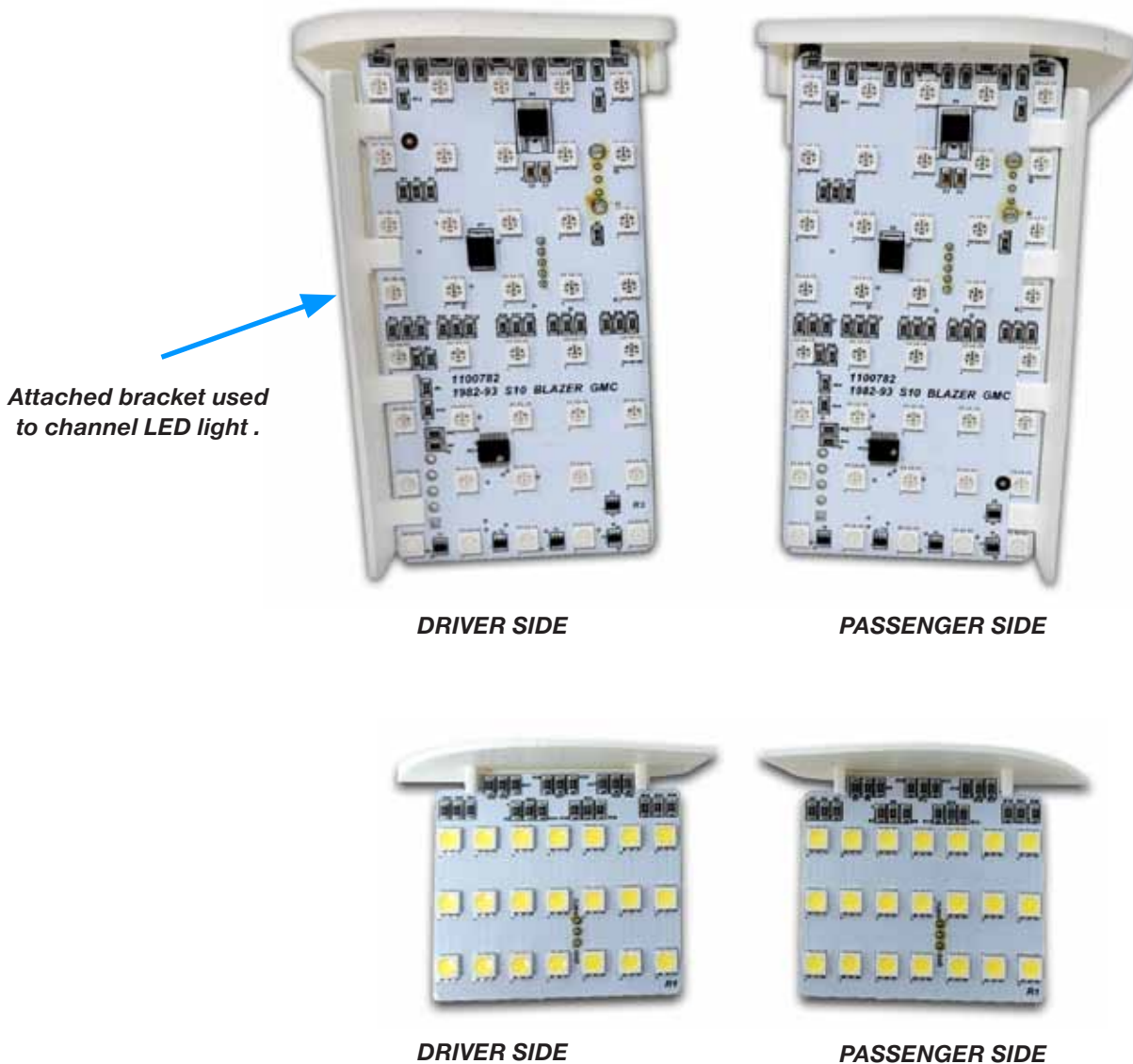

1. Modify the taillight housings for the BRAKE PANELS.

Remove the tail light housing assembly from the car. You will need to cut out openings on the side each of housing. Doing so will allow you to slide in the LED panels. Take your time marking the cutouts. It is also best to slowly trim away the necessary plastic.



PASSENGER SIDE housing shown

1. On the topside of the housing mark out a perimeter on the flat area. This will give access to allow the brake panel mounting.
2. Using a cutoff wheel or dremel tool cut out the marked perimeter area. Clean the edges of the opening and clean out all remaining debris. WEAR SAFETY GOGGLES!



3. Test fit the LED panel by sliding the panel assembly down into the opening.

Carefully work the panel assembly down by adjusting the position of the panel in slightly different directions.



4. The final position will have the panel assembly parallel and fit under the housing lip.

1. Modify the taillight housings for the REVERSE PANELS.

You will need to cut out openings on the bottom side each housing. Doing so will allow you to slide in the LED panels. Take your time marking the cutouts. It is also best to slowly trim away the necessary plastic.

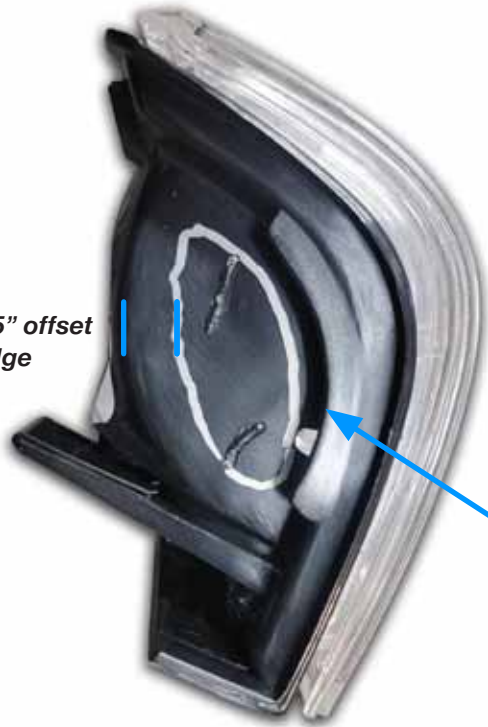

Make second mark 0.75" offset from the outside edge of the housing.

1. On the bottom side of the housing mark out the cutout like shown area on the flat area. This will give access to allow the reverse panel mounting.

2. Using a cutoff wheel or dremel tool cut out the marked perimeter area. Clean the edges of the opening and clean out all remaining debris. WEAR SAFETY GOGGLES!

First mark along perimeter of housing lip.

PASSENGER SIDE housing shown



3. Test fit the LED panel by sliding the panel assembly down into the opening.

The inner edge of the mounting bracket will butt up against the inner housing lip.

PASSENGER SIDE housing shown

2. Mount the LED panels.

Once you feel the fit is satisfactory and all functions work install the LED panels for one last time.



1. Plug the extension harness into the LED panel and slide the panel into the housing.

2. Apply silicone around the perimeter of the mounting brackets. Let the assembly fully dry for 24 hours.



3. Pull the other end of the extension harness through the socket hole. Use the included grommet and wrap it around the wires and press it into the socket hole.

The reverse light uses an 1156 plug adapter.



1. Review the wiring diagrams found on the last page.

Each LED panel needs five connections. Listed are the LED harness colors and their respective function. Note: Depending on make and harness, colors may not match.

ORANGE - Constant 12 volt power source

BLACK - Grounded to body









YELLOW - Driver side turn signal

GREEN - Passenger side turn signal

BROWN - Running/parking light signal

2. Find and access the front light socket and wires.

Splice the LED SIGNAL wires into the stock SIGNAL wires. Match the LED harness to the corresponding stock harness as shown below.

LED Harness	Function	Stock harness	Notes
 Green	Passenger side turn signal	 Green	The light socket ends on the car harness can be removed.
 Yellow	Driver side turn signal	 Yellow	The light socket ends on the car harness can be removed.
 Brown	Running/Park signal	 Brown	The light socket ends on the car harness can be removed.
 Orange	Constant 12 volt		Find power at fuse panel/trunk light/dome light/fused battery feed.
 Black	Ground		Ground to Body/chassis

3. Connect all the ground wires.

Connect all the ground wires together. Bolt them to the trunk latch support along with the original rear body harness ground. The ground connection must be good in order to the operate the LED panels.

4. Tuck and secure the spliced wires.

Take the spliced sections and fold them over to one side and tape them in place. This will allow you to place the wiring into loom or wrap the LED panel wiring tightly away.



1. Fold wires to one side.



2. Secure with electrical tape.

5. Splice the Orange power wire in with all LED panel Orange wires.

An Orange wire is supplied with a T-Tap. The orange wire must be supplied to a constant hot 12 volt supply for the LED circuitry to operate. The T-Tap connector is used to splice to the constant hot power source, like the dome light.

Splice the T-Tap connector into the the constant power wire, then plug the orange wire into the T-Tap. The other end of the orange wire is spliced into the LED panel orange wires.



1. Insert wire into T-Tap



2. Crimp with pliers



3. Plug connector into T-Tap

